

## Appendix 'A' – Standard Drawings

### ROADWAYS

- 3-01 24.0m Arterial Right of Way
- 3-02 20.0m Collector Right of Way without Frontage
- 3-03 20.0m Local Right of Way with Frontage
- 3-04 Rolled Face Curb and Gutter
- 3-05 Rolled Face Monolithic Sidewalk
- 3-06 Straight Face Monolithic Sidewalk
- 3-07 1.5m Separate Sidewalk
- 3-08 Curb Ramp

### SANITARY SEWER

- 4-01 Standard Manhole

### STORM SEWER

- 5-01 Standard Catchbasin

### WATERMAINS

- 6-01 Water Valve Installation
- 6-02 Hydrant Installation
- 6-03 Typical Anode Installation - Hydrant
- 6-04 Typical Anode Installation
- 6-05 Typical Single Service
- 6-06 Typical Double Service

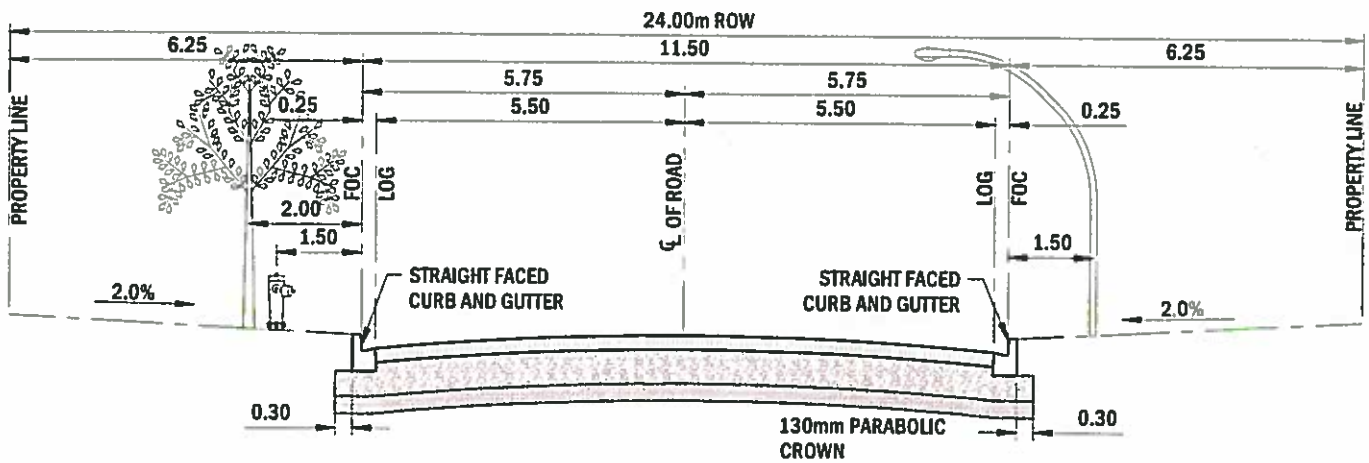

## 24.0m ARTERIAL ROW

MINIMUM ROAD STRUCTURE  
 125mm ASPHALT CONCRETE  
 300mm-20mm CRUSHED GRAVEL  
 150mm COMPACTED SUBGRADE OR  
 CEMENT STABILIZED CLAY SUBGRADE

ALL DIMENSIONS IN METRES

REVISIONS			24.0m ARTERIAL ROW			
DATE	DETAILS	BY	APPROVED:	CHECKED:	DATE:	
						DWG. NO.
						3-01

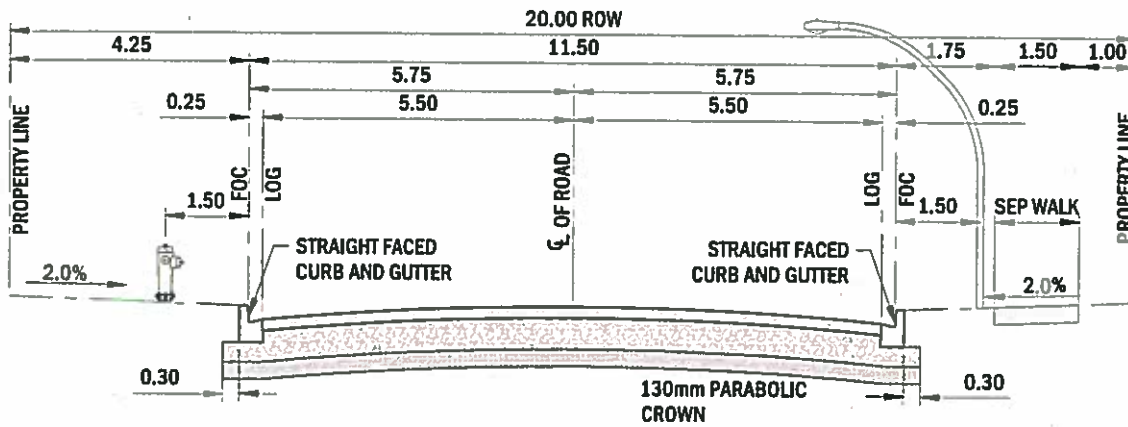

## 20.0m COLLECTOR ROW NO FRONTAGE

MINIMUM ROAD STRUCTURE  
 100mm ASPHALT CONCRETE  
 275mm-20mm CRUSHED GRAVEL  
 150mm COMPACTED SUBGRADE OR  
 CEMENT STABILIZED CLAY SUBGRADE

ALL DIMENSIONS IN METRES

REVISIONS		BY	20.0m COLLECTOR ROW NO FRONTAGE	
DATE	DETAILS			
			APPROVED:	DWG. NO.
			CHECKED:	3-02
			DATE:      SCALE: N.T.S.      DRAWN:	

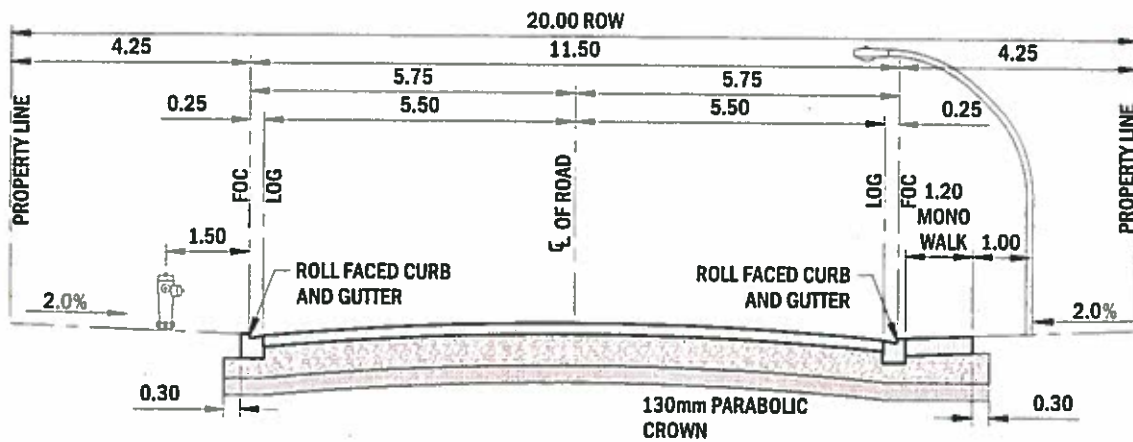

## 20.0m LOCAL ROW WITH FRONTAGE

MINIMUM ROAD STRUCTURE  
 100mm ASPHALT CONCRETE  
 275mm-20mm CRUSHED GRAVEL  
 150mm COMPACTED SUBGRADE OR  
 CEMENT STABILIZED CLAY SUBGRADE

ALL DIMENSIONS IN METRES

REVISIONS			20.0m LOCAL ROW WITH FRONTAGE			
DATE	DETAILS	BY				
			APPROVED:			DWG. NO.
			CHECKED:			3-03
			DATE:	SCALE: N.T.S.	DRAWN:	

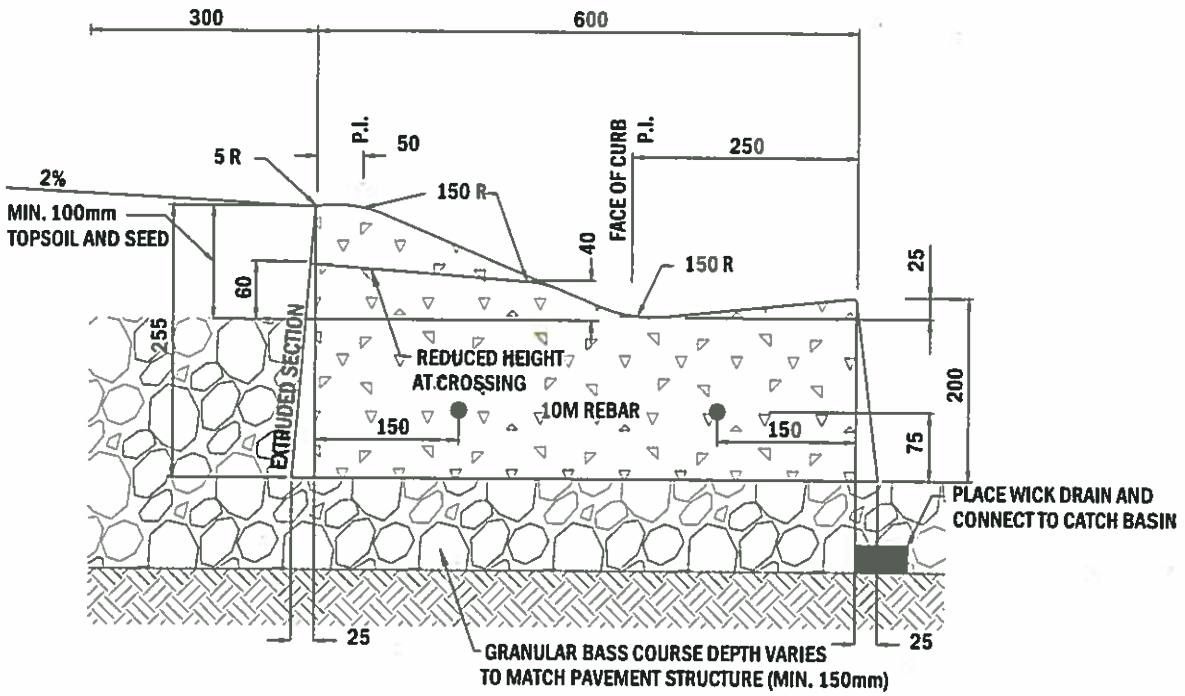

ALL DIMENSIONS IN MILLIMETRES

REVISIONS			ROLL FACE CURB AND GUTTER			
DATE	DETAILS	BY				
			APPROVED:			DWG. NO.
			CHECKED:			3-04
			DATE:	SCALE: N.T.S.	DRAWN:	

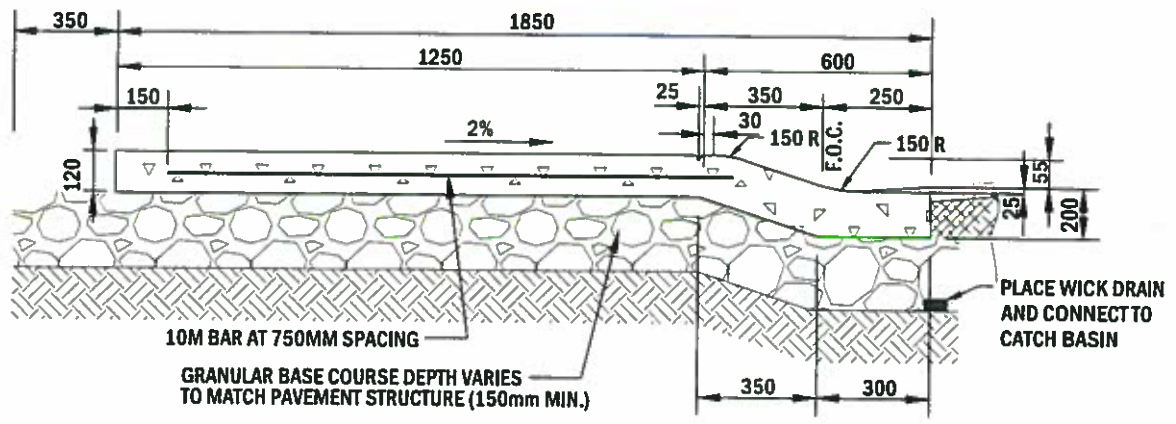

ALL DIMENSIONS IN MILLIMETRES

REVISIONS		ROLLED FACE MONOLITHIC SIDEWALK			
DATE	DETAILS	BY	APPROVED:	DWG. NO.	
			CHECKED:	3-05	
			DATE:		
			SCALE: N.T.S.		
			DRAWN:		

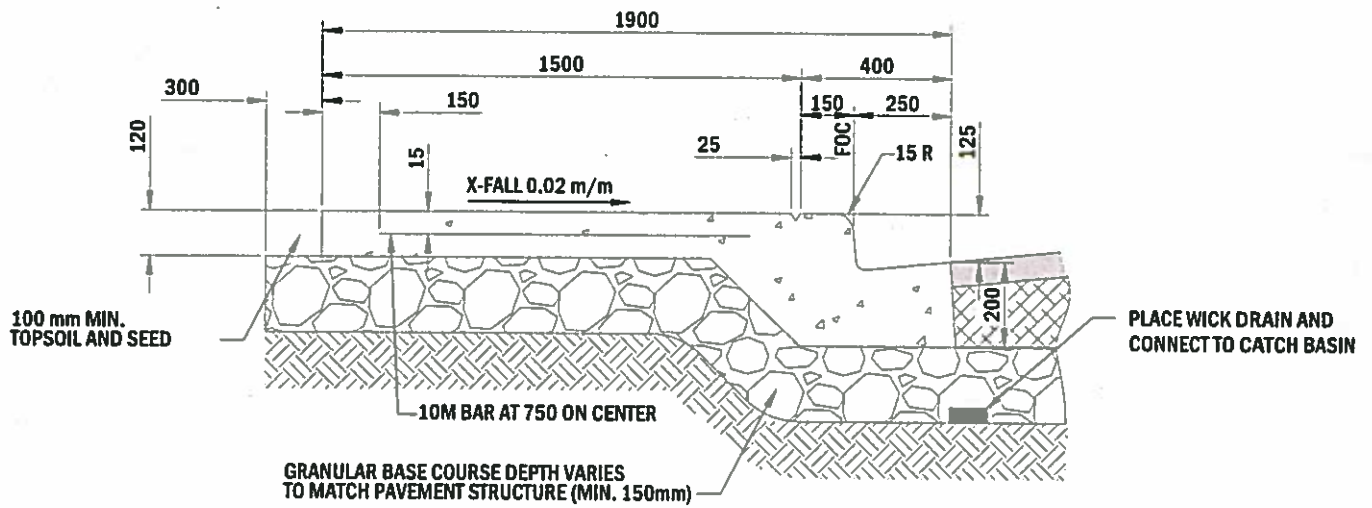

ALL DIMENSIONS IN MILLIMETRES

REVISIONS		BY	STRAIGHT FACED MONOLITHIC SIDEWALK	
DATE	DETAILS			
			APPROVED:	3-06
			CHECKED:	
			DATE:      SCALE: N.T.S.      DRAWN:	

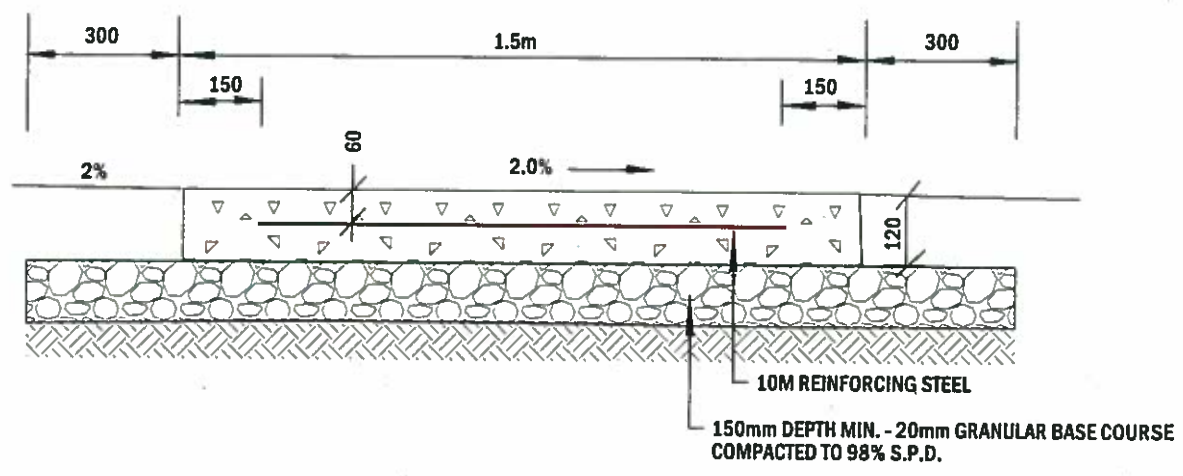
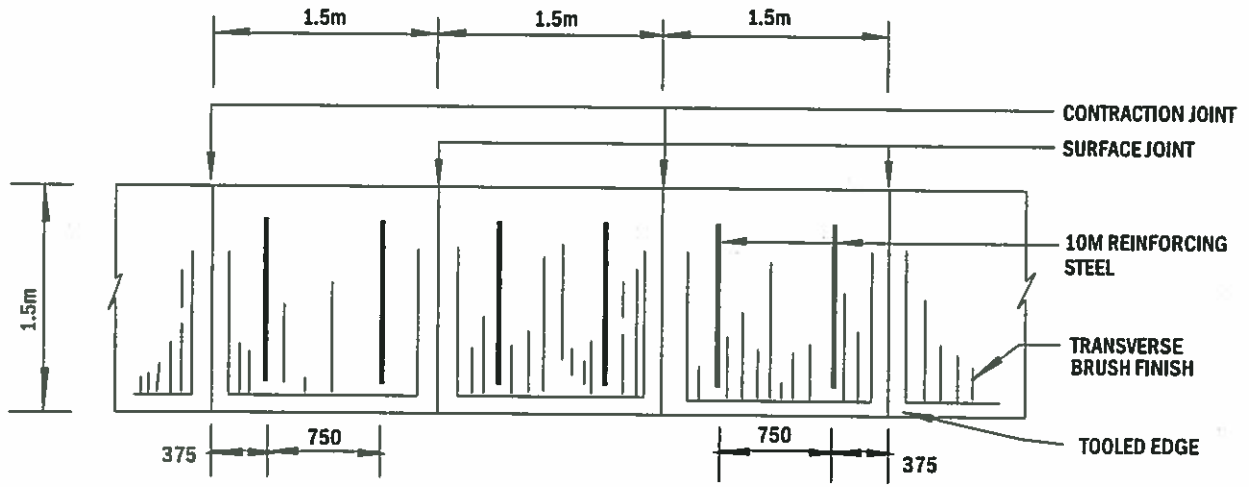

ALL DIMENSIONS IN MILLIMETRES

REVISIONS			1.5m SEPARATE SIDEWALK			
DATE	DETAILS	BY				
			APPROVED:			DWG. NO.
			CHECKED:			3-07
			DATE:	SCALE: N.T.S.	DRAWN:	



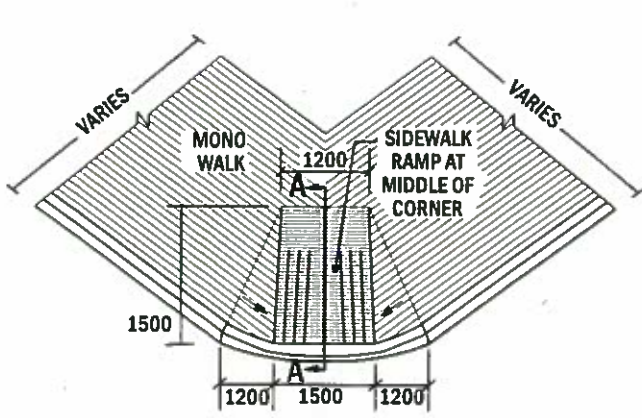

**TYPE A**

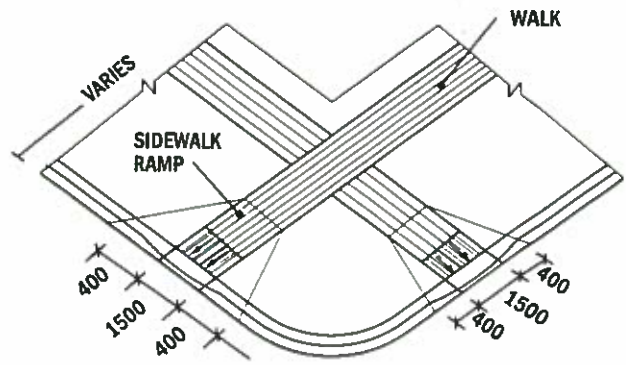

**TYPE B**

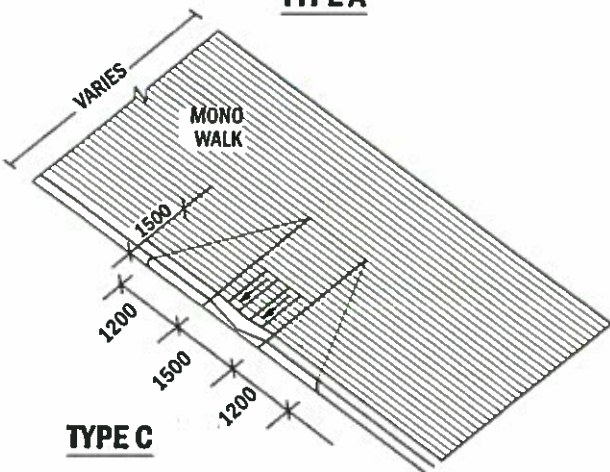

**TYPE C**

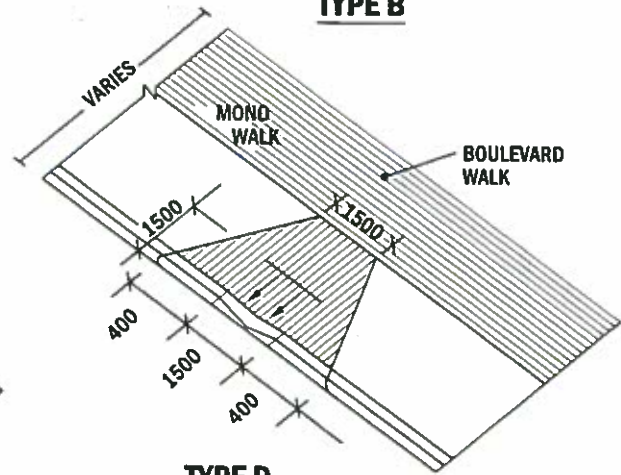

**TYPE D**

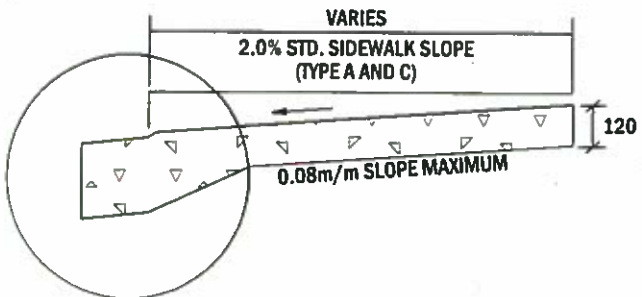

**TYPICAL CROSS-SECTION A-A**

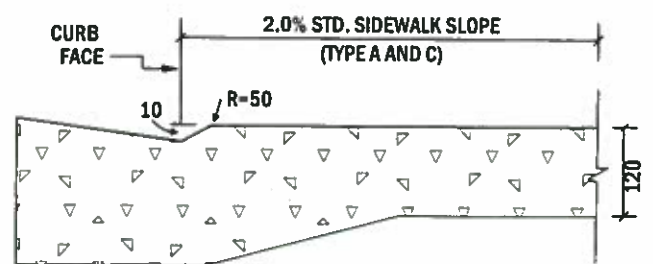

**DETAIL**

**NOTES:**

1. TOOLED GROOVES 5mm WIDE X 10mm DEEP, BROOM FINISH GROOVE SPACING 150mm O.C. ADJACENT TO CURB.
2. WHERE RAMP IS TO BE USED AS A TRANSITION, USE THE CENTRE OF THE 150mm RAMP AS THE CENTRE OF THE TRANSITION.
3. WHERE CURB FACE IS 200mm, DISTANCE OF FLARE SHOULD BE 1600mm.
4. CURBS AND RAMPS TO BE POURED MONOLITHICALLY.

ALL DIMENSIONS IN METRES

REVISIONS			CURB RAMP			
DATE	DETAILS	BY				
			APPROVED:			DWG. NO.
			CHECKED:			3-08
			DATE:	SCALE: N.T.S.	DRAWN:	

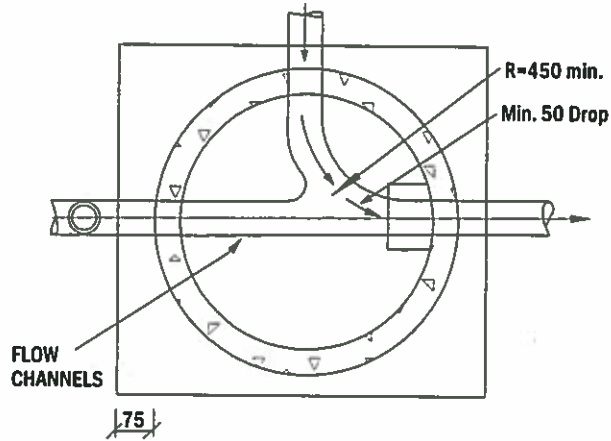
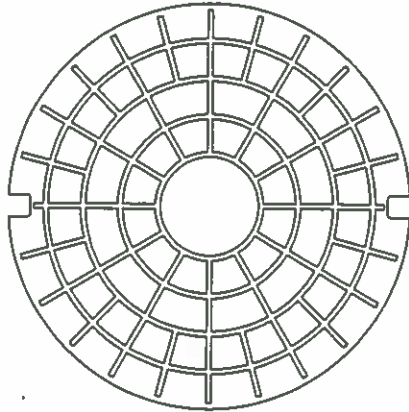

**STANDARD FRAME & COVER**

Use Norwood N.F.80 or Trojan T.F 80 on all manholes in roadways or walks

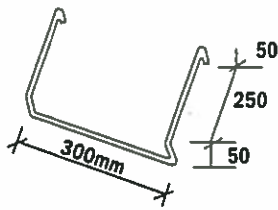

**SAFETY TYPE M.H. RUNG**

GALVANIZED IRON SPACING TO BE 400mm CENTRE TO CENTRE

USE DURASEAL FOR WATERTIGHT COUPLING BETWEEN MH AND PVC PIPE

COMPACTED GRANULAR FILL

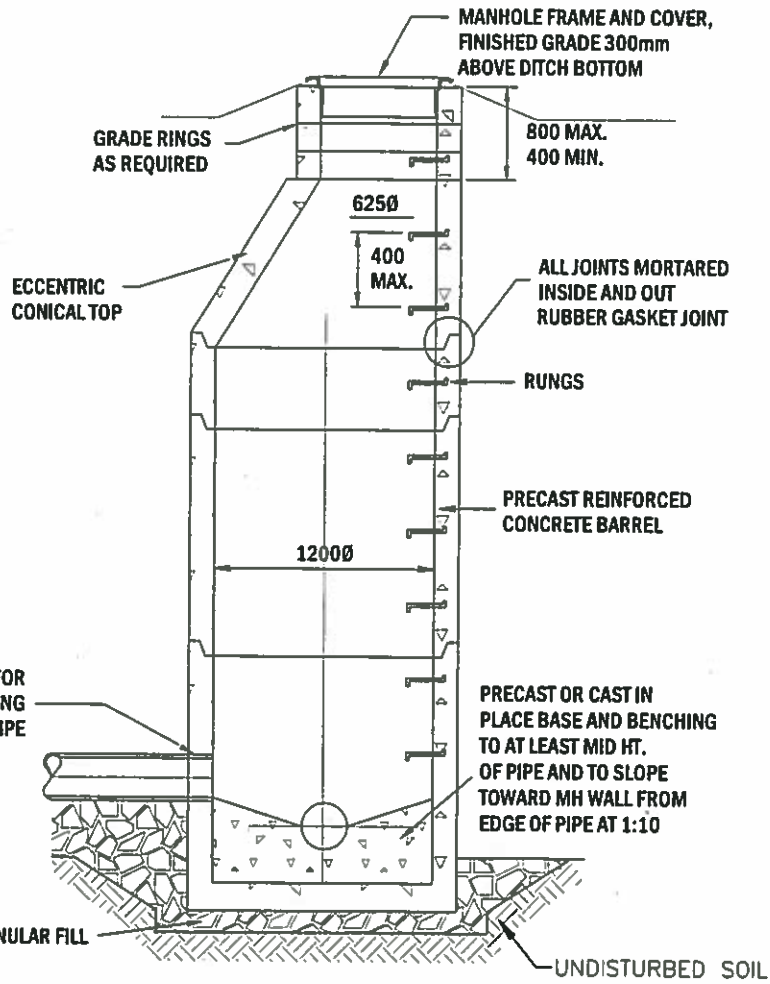

NOTES:  
1. MANHOLES OF DEPTH GREATER THAN 7m REQUIRE AN ALUMINUM SAFETY PLATFORM.

ALL DIMENSIONS IN MILLIMETRES

REVISIONS			STANDARD MANHOLE			
DATE	DETAILS	BY				
			APPROVED:			DWG. NO.
			CHECKED:			4-01
			DATE:	SCALE: N.T.S.	DRAWN:	

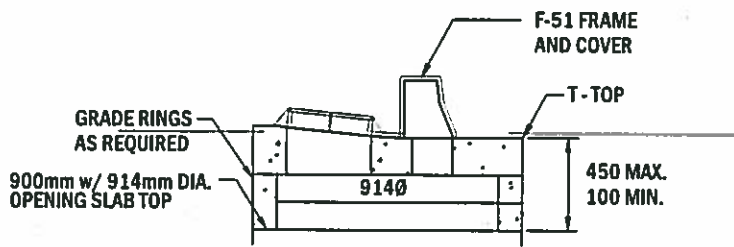

**F-51**

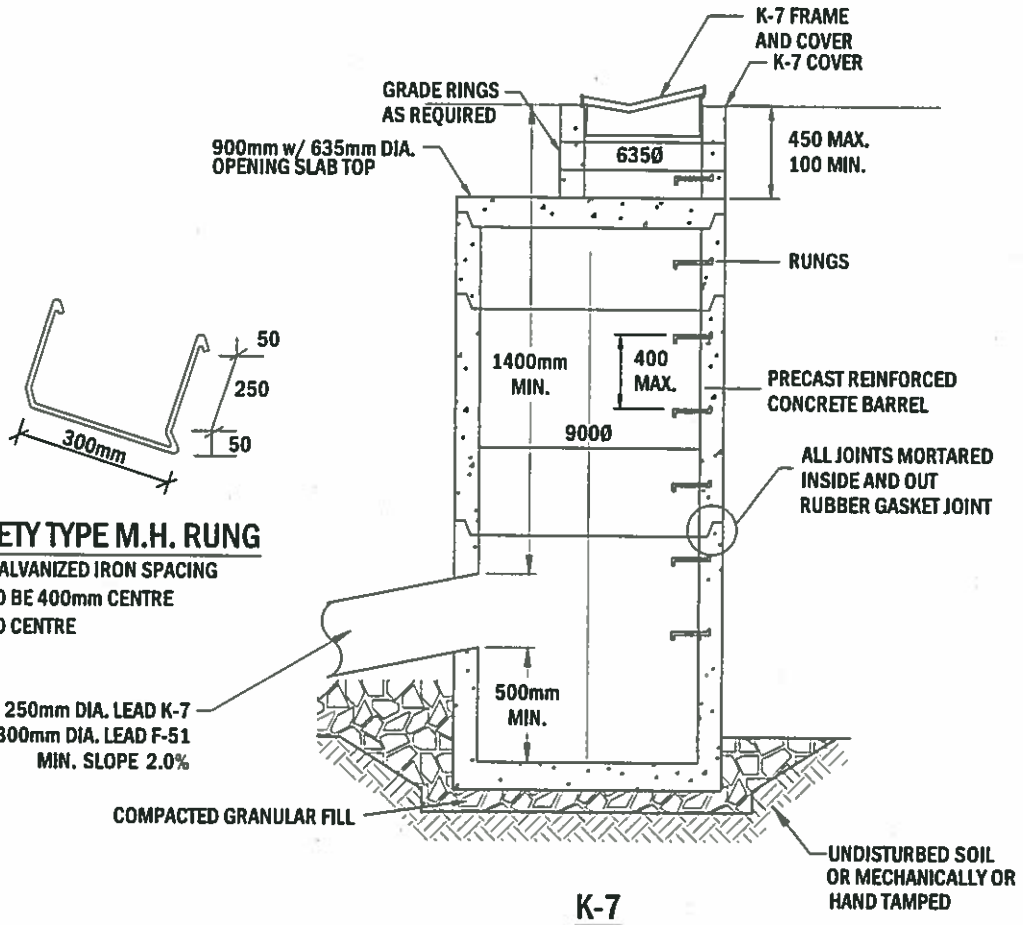

**K-7**

ALL DIMENSIONS IN MILLIMETRES

REVISIONS			STANDARD CATCHBASIN			
DATE	DETAILS	BY				
			APPROVED:			DWG. NO.
			CHECKED:			5-01
			DATE:	SCALE: N.T.S.	DRAWN:	

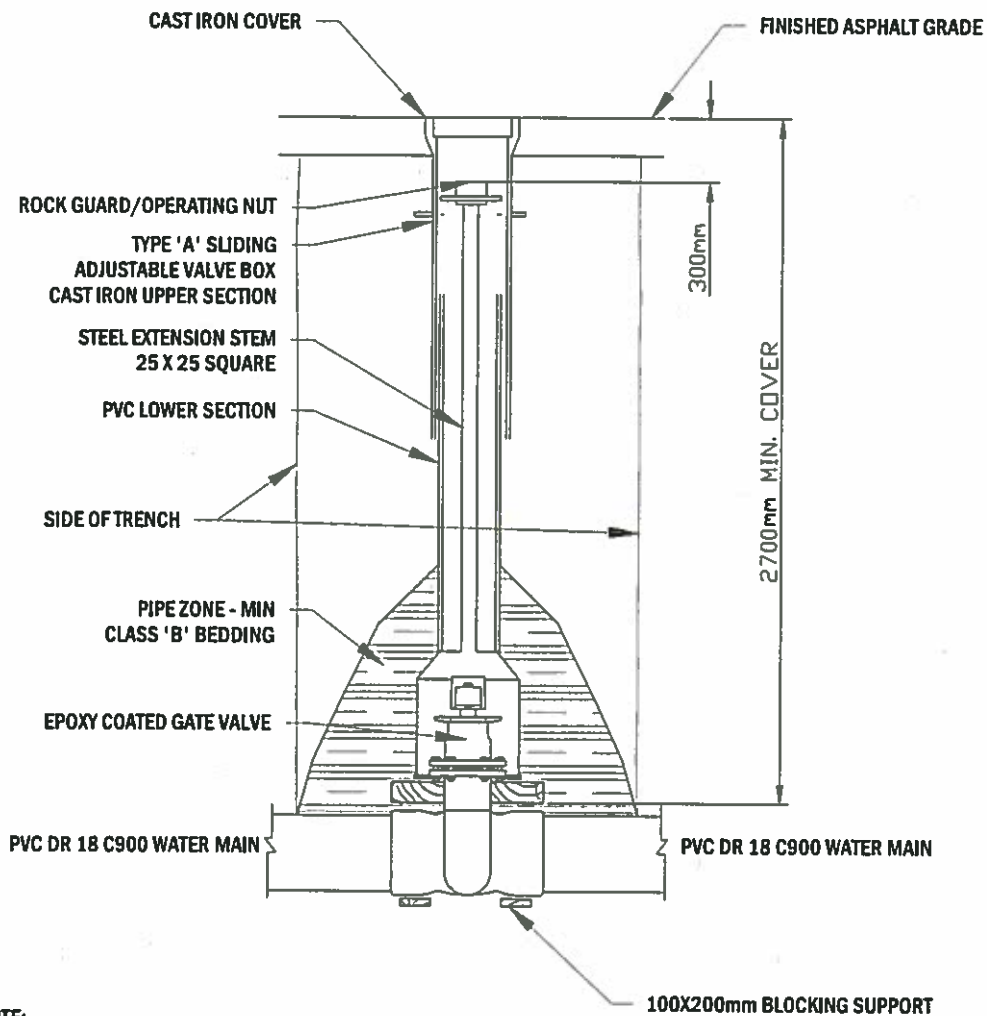

**NOTE:**

1. VALVE TO BE ADEQUATELY PROTECTED AGAINST LATERAL MOVEMENT WITH CONCRETE THRUST BLOCKING.
2. ALL VALVES ARE TO BE EPOXY COATED WITH STAINLESS BOLTS AND CATHODICALLY PROTECTED WITH MIN. 2.3kg ZINC ANODE.

ALL DIMENSIONS IN METRES

REVISIONS			WATER VALVE INSTALLATION			
DATE	DETAILS	BY				
			APPROVED:			DWG. NO.
			CHECKED:			6-01
			DATE:	SCALE: N.T.S.	DRAWN:	

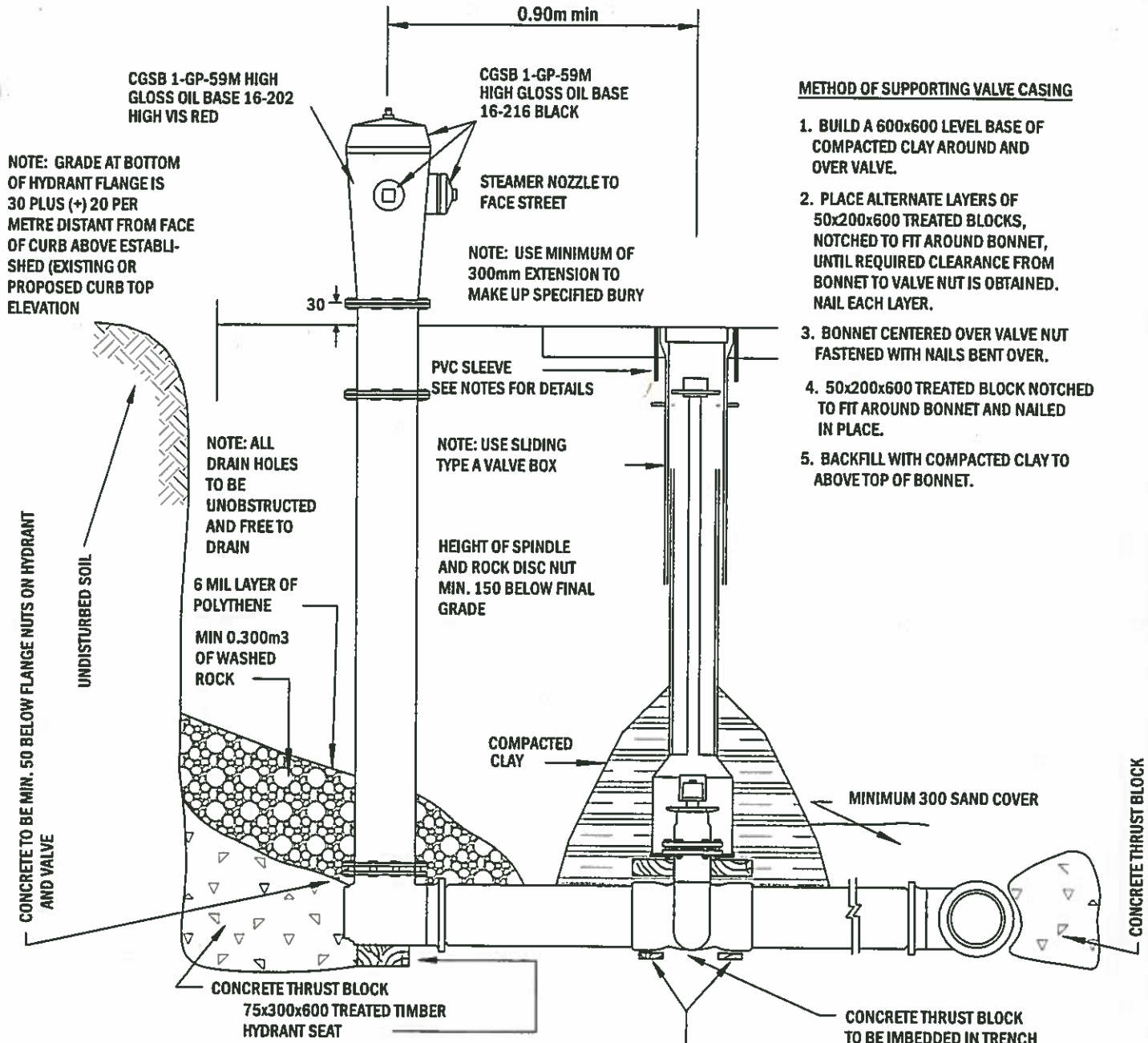

**METHOD OF SUPPORTING VALVE CASING**

1. BUILD A 600x600 LEVEL BASE OF COMPACTED CLAY AROUND AND OVER VALVE.
2. PLACE ALTERNATE LAYERS OF 50x200x600 TREATED BLOCKS, NOTCHED TO FIT AROUND BONNET, UNTIL REQUIRED CLEARANCE FROM BONNET TO VALVE NUT IS OBTAINED. NAIL EACH LAYER.
3. BONNET CENTERED OVER VALVE NUT FASTENED WITH NAILS BENT OVER.
4. 50x200x600 TREATED BLOCK NOTCHED TO FIT AROUND BONNET AND NAILED IN PLACE.
5. BACKFILL WITH COMPACTED CLAY TO ABOVE TOP OF BONNET.

NOTE: GRADE AT BOTTOM OF HYDRANT FLANGE IS 30 PLUS (+) 20 PER METRE DISTANT FROM FACE OF CURB ABOVE ESTABLISHED (EXISTING OR PROPOSED CURB TOP ELEVATION

NOTE: USE MINIMUM OF 300mm EXTENSION TO MAKE UP SPECIFIED BURY

NOTE: ALL DRAIN HOLES TO BE UNOBSTRUCTED AND FREE TO DRAIN

NOTE: USE SLIDING TYPE A VALVE BOX

HEIGHT OF SPINDLE AND ROCK DISC NUT MIN. 150 BELOW FINAL GRADE

CONCRETE TO BE MIN. 50 BELOW FLANGE NUTS ON HYDRANT AND VALVE

6 MIL LAYER OF POLYTHENE  
MIN 0.300m<sup>3</sup> OF WASHED ROCK

COMPACTED CLAY

MINIMUM 300 SAND COVER

CONCRETE THRUST BLOCK  
75x300x600 TREATED TIMBER  
HYDRANT SEAT

CONCRETE THRUST BLOCK  
TO BE IMBEDDED IN TRENCH  
WALL 50 BELOW FLANGE NUTS

50X100 BLOCKING SUPPORTS VALVE  
INDEPENDENTLY OF PIPE UNTIL CONCRETE IS SET

- NOTES:
1. HYDRANTS ARE TO BE McAVITY OR CANADA VALVE.
  2. ALL HYDRANTS ARE REQUIRED TO HAVE A 150mm STORTZ CONNECTION.
  3. HYDRANTS TO BE EQUIPPED WITH A STORTZ INTERNAL LUG QUICK CONNECTION NOZZLE OR EQUIVALENT.
  4. HYDRANT DRAIN HOLES TO BE PLUGGED IN AREAS OF HIGH GROUND WATER.
  5. ALL BOLTS TO BE STAINLESS STEEL, WRAPPED WITH DENSO MASTIC AND DENSO TAPE.
  6. PVC SLEEVE TO BE USED WHEN VALVE IS INCORPORATED WITHIN CONCRETE.
  7. CATHODIC PROTECTION REQUIRED.

ALL DIMENSIONS IN METRES

REVISIONS			HYDRANT INSTALLATION			
DATE	DETAILS	BY				
			APPROVED:			DWG. NO.
			CHECKED:			6-02
			DATE:	SCALE: N.T.S.	DRAWN:	

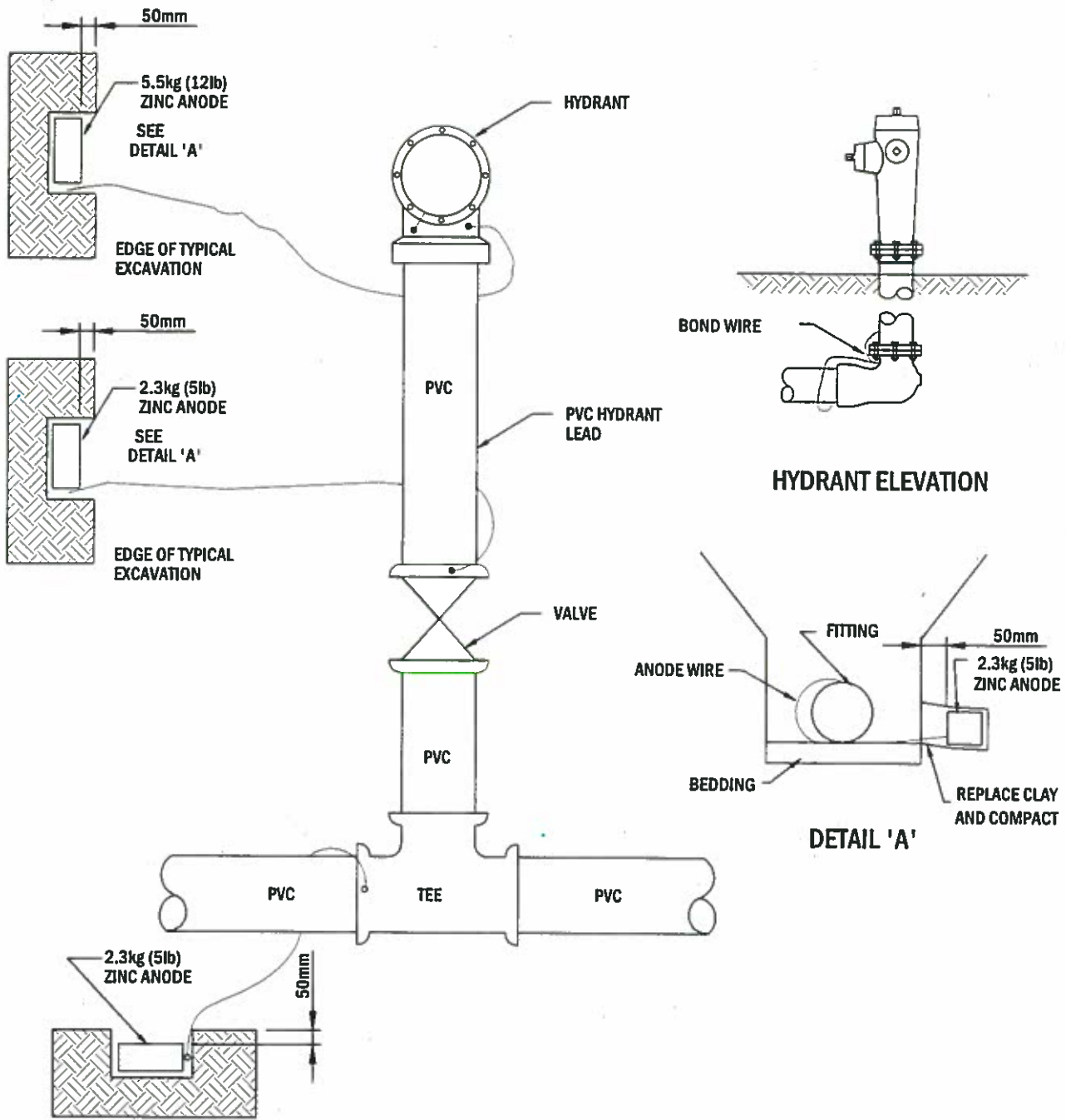

**NOTES:**

1. MINIMUM DISTANCE FROM ANODE TO PIPE, FITTING, VALVE, OR HYDRANT IS 150mm.
2. INSTALL ANODE AT APPROX. PIPE DEPTH IN NATIVE SOIL.
3. ZINC ANODES TO BE EMBEDDED INTO TRENCH WALL TO PROVIDE FOR A MINIMUM OF 50mm OF NATIVE CLAY COMPLETELY SURROUNDING THE ANODE.
4. ANODES TO BE AT LEAST 300mm CLEAR OF THRUST BLOCK.

ALL DIMENSIONS IN METRES

REVISIONS			TYPICAL ANODE INSTALLATION	
DATE	DETAILS	BY		
			APPROVED:	DWG. NO.
			CHECKED:	6-03
			DATE:      SCALE: N.T.S.      DRAWN:	



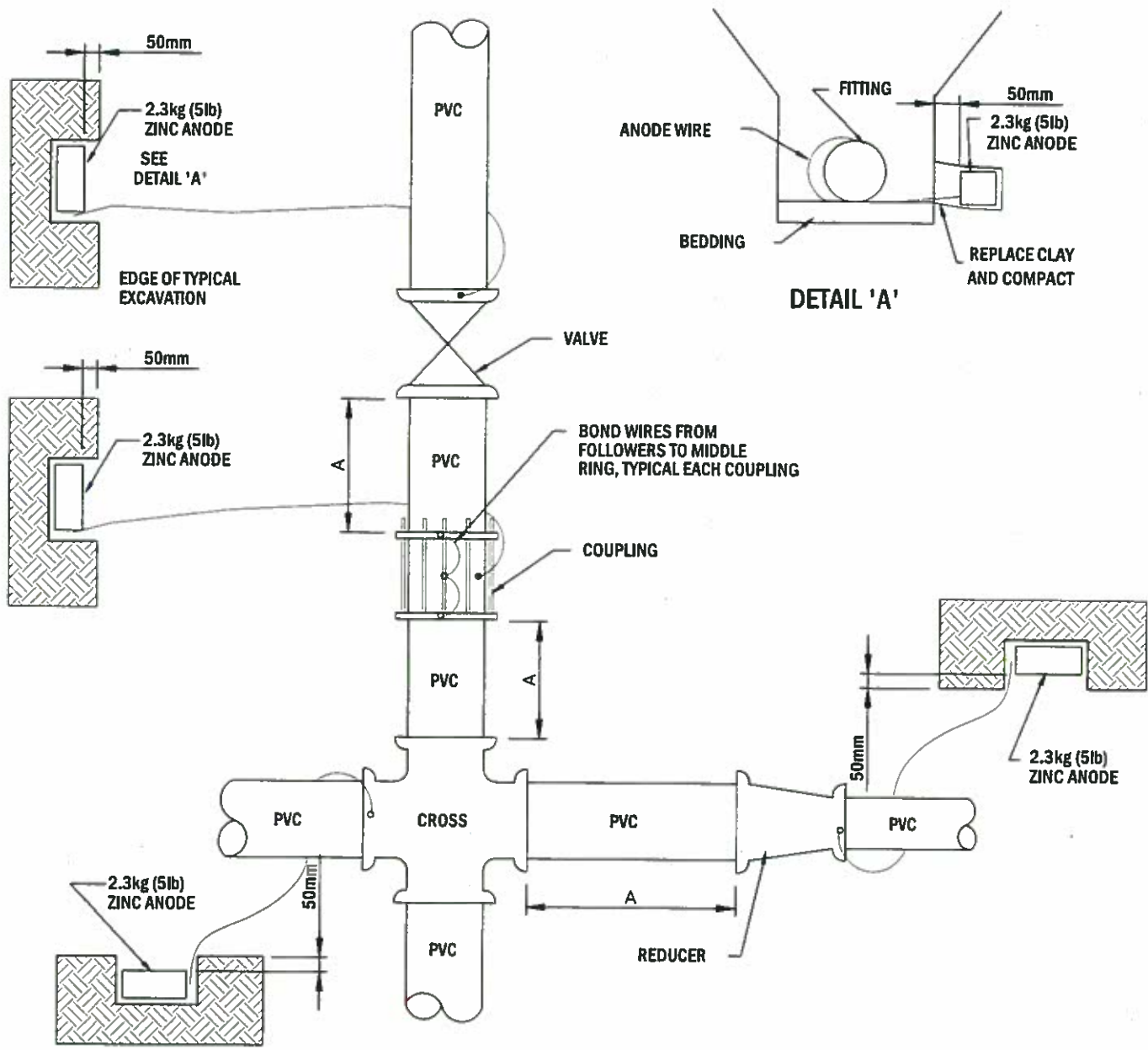

**NOTES:**

1. MINIMUM DISTANCE FROM ANODE TO PIPE, FITTING, VALVE, OR HYDRANT IS 150mm.
2. INSTALL ANODE AT APPROX. PIPE DEPTH IN NATIVE SOIL.
3. BOND WIRES MAY BE USED TO PROTECT UP TO TWO FITTINGS WITH ONE ANODE WHEN DIMENSION 'A' DOES NOT EXCEED ONE (1) METER.
4. ALL ZINC ANODES ON FITTINGS AND VALVES ARE 2.3kg (5lb).
5. ZINC ANODES TO BE EMBEDDED INTO TRENCH WALL TO PROVIDE FOR A MINIMUM OF 50mm OF NATIVE CLAY COMPLETELY SURROUNDING THE ANODE.
6. ANODES TO BE AT LEAST 300mm CLEAR OF THRUST BLOCK.

ALL DIMENSIONS IN METRES

REVISIONS			TYPICAL ANODE INSTALLATION			
DATE	DETAILS	BY				
			APPROVED:			DWG. NO.
			CHECKED:			6-04
			DATE:	SCALE: N.T.S.	DRAWN:	

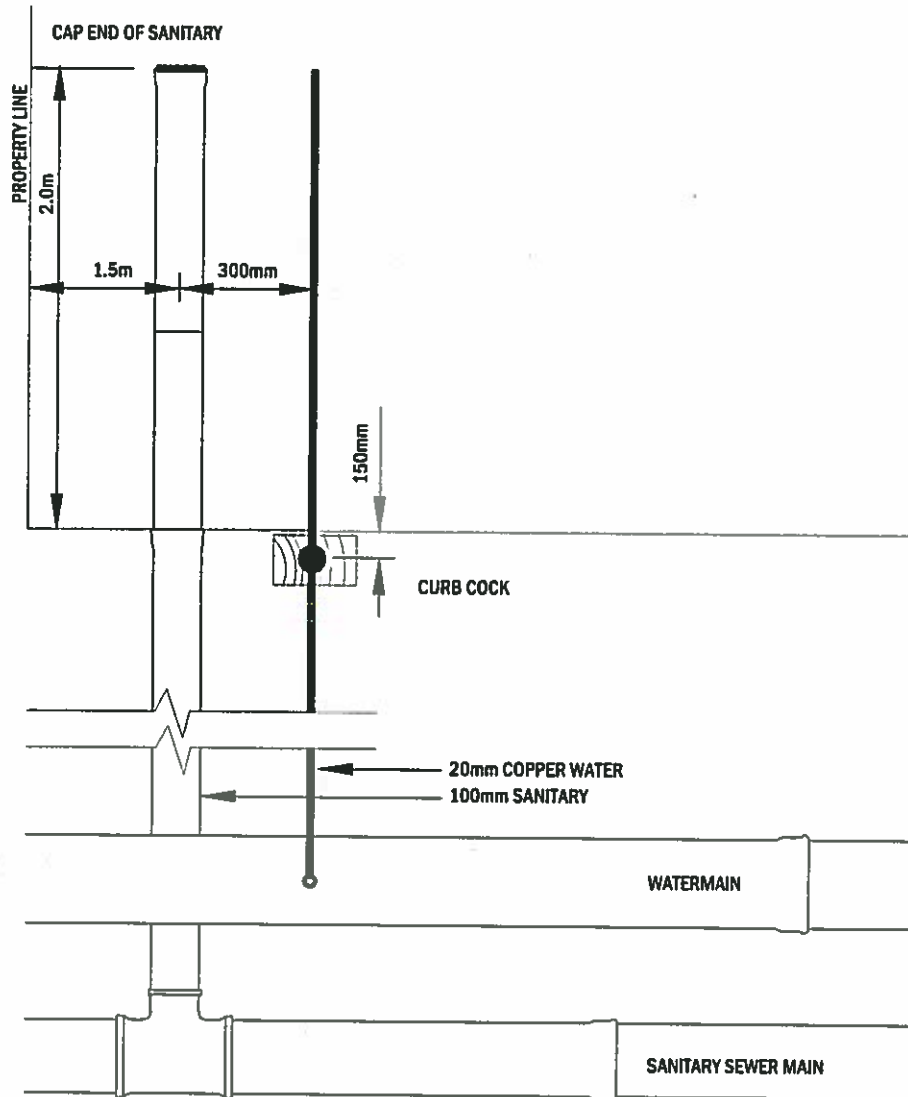

**NOTES:**

- THE TOWN ACCEPTS NO RESPONSIBILITY FOR THE CONSTRUCTION OR MAINTENANCE OF THE SERVICES BEYOND PROPERTY LINE
- THE END OF THE COPPER WATER SERVICE SHOULD NOT BE CRIMPED CLOSED. PERMIABLE FILTER CLOTH WILL BE USED TO PREVENT INTRUSION OF DEBRIS AND TO ALLOW TESTING FLOW OF CURBSTOP.
- MARK CURB COCK WITH A 50x100x750mm STAKE PAINTED RED.

ALL DIMENSIONS IN METRES

REVISIONS			TYPICAL SINGLE SERVICE			
DATE	DETAILS	BY				
			APPROVED:			DWG. NO.
			CHECKED:			6-05
			DATE:	SCALE: N.T.S.	DRAWN:	



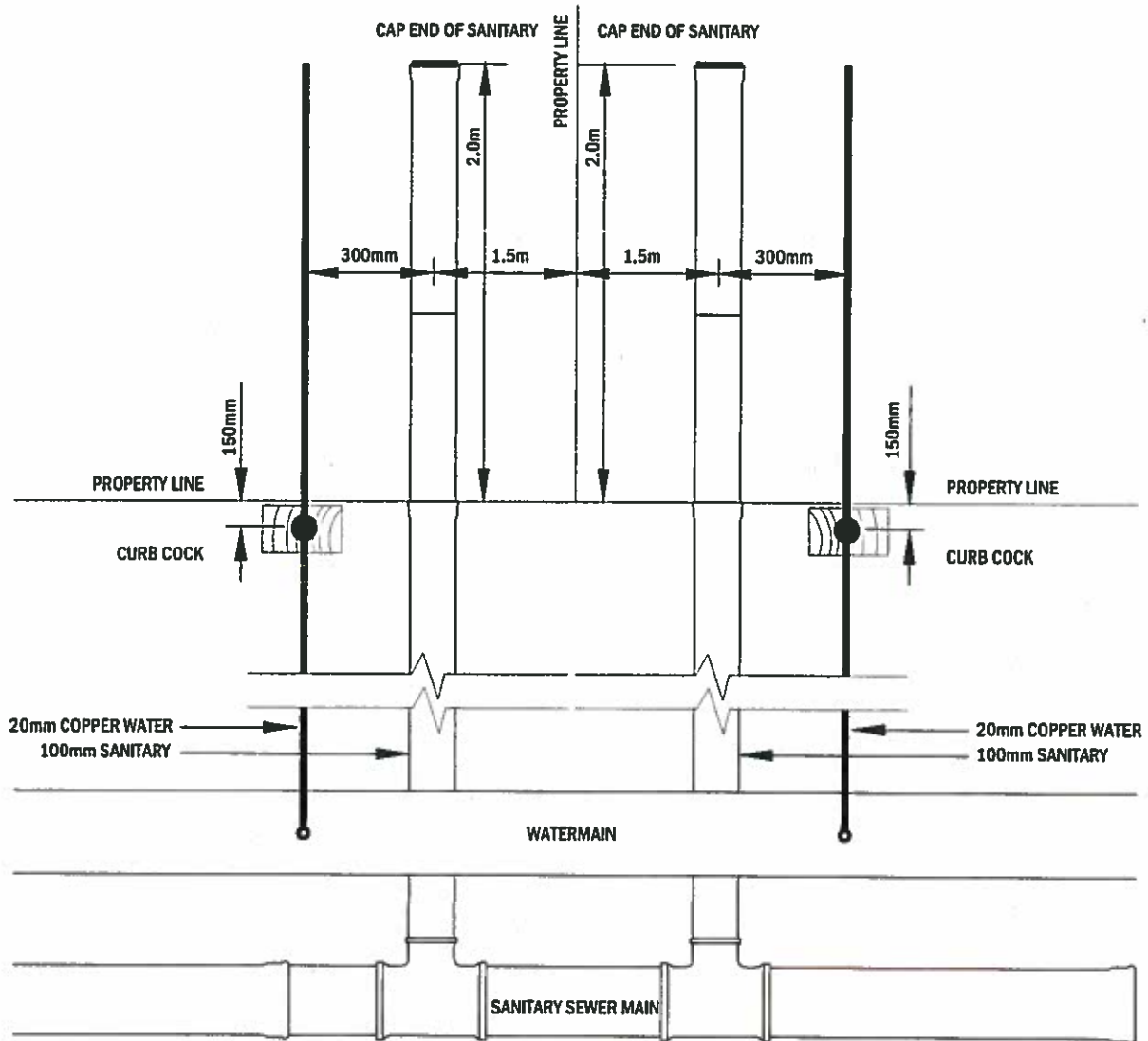

**NOTES:**

- THE TOWN ACCEPTS NO RESPONSIBILITY FOR THE CONSTRUCTION OR MAINTENANCE OF THE SERVICES BEYOND PROPERTY LINE
- THE END OF THE COPPER WATER SERVICE SHOULD NOT BE CRIMPED CLOSED, PERMIABLE FILTER CLOTH WILL BE USED TO PREVENT INTRUSION OF DEBRIS AND TO ALLOW TESTING FLOW OF CURBSTOP.
- MARK CURB COCK WITH A 50x100x750mm STAKE PAINTED RED.

ALL DIMENSIONS IN METRES

REVISIONS			TYPICAL DOUBLE SERVICE			
DATE	DETAILS	BY				
			APPROVED:			DWG. NO.
			CHECKED:			6-06
			DATE:	SCALE: N.T.S.	DRAWN:	